

B. F. Sturtevant,
Cutting Veneers,
No. 26,627, Patented Dec. 27, 1859.

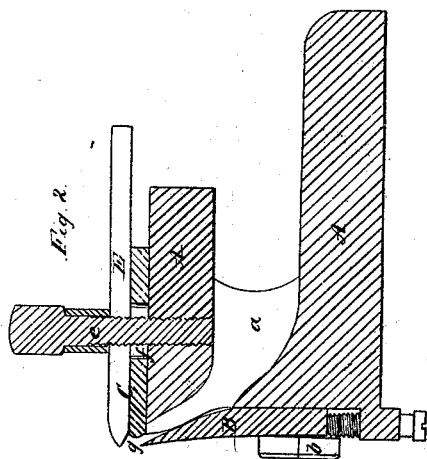
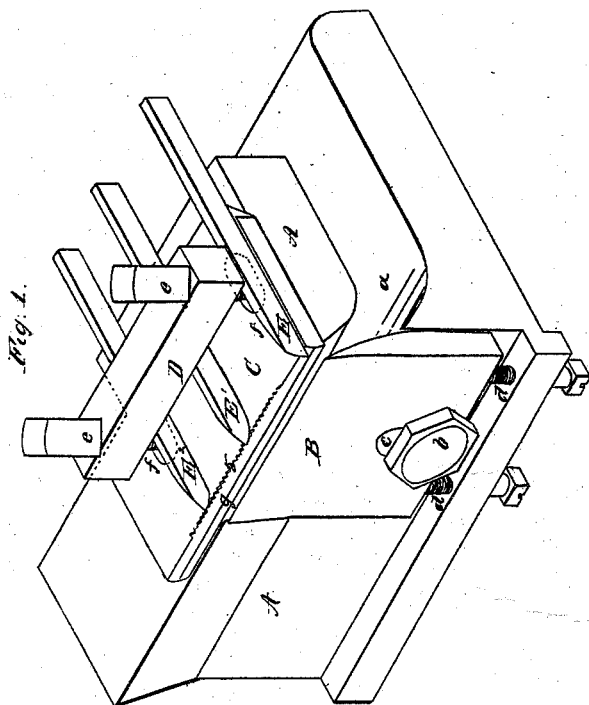

Witnesses
Thos. R. Road
J. C. Fishman

Inventor,
B. F. Sturtevant

UNITED STATES PATENT OFFICE.

B. F. STURTEVANT, OF BOSTON, MASSACHUSETTS.

LATHE ATTACHMENT FOR CUTTING VENEERS.

Specification of Letters Patent No. 26,627, dated December 27, 1859.

To all whom it may concern:

Be it known that I, B. F. STURTEVANT, of Boston, in the county of Suffolk and State of Massachusetts, have invented certain Improvements in Tools for Cutting Sheets or Strips from the Surface of Cylinders or Blocks of Wood, of which the following is a full, clear, and exact description, reference being had to the accompanying drawings, making part of this specification, in which—

Figure 1 is a view of the cutting tools and the block or rest to which they are attached. Fig. 2 a transverse vertical section through the same.

Veneers have been cut, both from the surface of a cylinder of wood revolved against a knife, and also from a block of wood which was carried back and forth by reciprocating machinery over the knife. Sheets of wood could be thus cut, when they were quite thin, (as for veneers) but when a thicker sheet or strip was to be cut from the wood, either around the log, or across the grain of the block, and where a thicker knife was required; the wood was liable to be split partially or entirely through the thickness of the sheet, which did not then retain sufficient strength for the uses to which it was to be applied (for example, stuff for picture frame backs, bottoms of drawers, and when cut narrow for blanks of shoe pegs). To remedy this is the object of my present invention which consists in applying a considerable amount of pressure to the surface of the wood, in the immediate vicinity of the cutting edge of the knife; by which means the splitting or crippling of the wood is prevented; and this pressure I apply by means of a presser bar, the position of which is so adjusted with respect to the edge of the knife, that the space between the bar and knife shall be less than the distance which the knife is fed up at each revolution of the log, or each vibration of the block.

That others skilled in the art may understand and use my invention I will proceed to describe the manner in which I have carried out the same.

In the said drawings A is a block of metal which is attached to or occupies the place of the ordinary slide rest in a lathe. This block is cut away at *a* to form a throat for the passage of the sheet of wood, the length of this recess corresponding with the length of the knife B, which is secured to the front of the block A by a screw *b* passing through

a slot *c* in the knife. This knife is adjusted in height by set screws *d*, and is beveled, as shown in Fig. 2.

A flat presser bar C is secured to the top of the block A, by means of a clamp D and screws *e* passing through slots *f* in the bar, which allows the position of this bar to be adjusted. Its front edge *g* is beveled as shown in Fig. 2, the bevel on the lower side corresponding or nearly so with the bevel on the back of the knife B. The upper side at its front edge is turned up, forming a lip or rabbet *h* along this edge which is notched as shown in Fig. 1. The chisels or cutters E, E¹, E² rest on the presser bar C and are held firmly in position by the clamp D, their front or cutting ends resting in the notches *h* which prevents any undue vibration. These cutters are only used when the width of the sheet cut by the knife B is less than the length of the cylinder or block; or when the sheet is to be divided into narrow ribbons.

Operation: The following is the operation of the above described tools, and the machinery connected therewith when cutting sheets from a cylinder of wood. The log to be operated upon, having been previously turned to a cylinder, is revolved slowly in a lathe; the block A is attached to the slide rest, or occupies a similar position at the front of the lathe, so that it can be moved lengthwise of the lathe for the knife B to operate on different parts of the length of the log. This knife is placed with its cutting edge in or near a horizontal plane passing through the axis of the log. The block A is fed horizontally by suitable mechanism toward the log, for this purpose I use screws and gears, which may be varied to give the block A the proper feed relative to the speed at which the log is revolved, to cause the knife B to cut into the log to a depth sufficient to produce the sheet of wood of the required thickness. The sheet of wood thus produced passes down through the throat *a* and is removed by the attendant. The screws and gears regulate the thickness of the sheet to be cut, but I set the presser bar C, so that the space between its edge *g* and the cutting edge of the knife B shall be less than the distance which the knife is fed for a single revolution of the log, or less than the thickness of sheet due to the feed, so as to cause the edge *g* to be pressed with a considerable degree of force against the exte-

rior surface of the wood, opposite to or immediately in advance of the edge of the knife. The position of the edge *g* with respect to the edge of the knife being governed
 5 by the thickness of the sheet being cut and the quality of the wood; the thicker the sheet and the tougher the wood, the higher it may be raised above the plane in which the knife is fed toward the axis of the log.

10 I have found in practice that when the pressure is not applied to the wood in the vicinity of the edge of the knife B when cutting around the log, as above described that the sheet taken off is so crippled by the
 15 thickness of the knife, that it breaks easily.

Instead of securing the presser bar C rigidly to the block A a strong spring may be employed to press it up with sufficient force against the wood being cut.

20 The cutters E, E', E² are used to separate the edge of the sheet from the log, and to divide it into ribbons of the required width, the cutter E is placed opposite to the inner end of the knife B and cuts in a little in advance of the knife separating the sheet at
 25 its edge from the body of the log, leaving the end of the log where it has cut, square ready for the next cut of the knife B. (This cutter as well as the end of the knife B is set

flush with the end of the block A.) The
 30 cutter E² squares the end of the log when making the first cut around it with the knife B, leaving the outer edge of the sheet straight; or if the end of the log has been squared previously, this cutter may be dis-
 35 pensed with. The cutter E' divides the sheet in the middle of its width. Any suitable number of these cutters may be employed.

These tools may be applied in a similar
 40 manner to cut sheets or ribbons from a block of wood, the feed in this case being intermittent.

What I claim as my invention and desire
 45 to secure by Letters Patent is—

1. Compressing the wood in the immediate vicinity of the edge of the knife by means of the presser bar C or its equivalent, arranged and operating substantially as set
 50 forth.

2. I claim the cutters E, E', E² or their substantial equivalents for the purpose specified.

B. F. STURTEVANT.

Witnesses:

THOS. R. ROACH,
 P. E. TESCHEMACHER.